

SC-12

Scarifier Head

Attachment



3706 MILL CREEK DRIVE NE
COMSTOCK PARK, MI 49321
VOICE: (616) 447-9076
FAX: (616) 447-9078
E-MAIL: INFO@BWMANUFACTURING.COM
WWW.BWMANUFACTURING.COM

Version 09/2014

Part# F-1208

INDEX

INTRODUCTION.....	PAGE 3
TERMS & CONDITIONS OF SALE.....	PAGE 4 - 5
HAZ-MAT SAFTEY WARNING.....	PAGE 6
WARRANTY BREAKDOWN.....	PAGE 7
SCARIFIER HEAD INSTALLATION.....	PAGE 8 - 9
SCARIFIER HEAD OPERATION.....	PAGE 10
SCARIFIER HEAD SERVICE.....	PAGE 11
SCARIFIER HEAD PARTS.....	PAGE 12 - 14

INTRODUCTION

FORWARD

WARNING READ THIS MANUAL CAREFULLY PRIOR TO OPERATING THE EQUIPMENT IN ORDER TO UNDERSTAND HOW TO OPERATE AND SERVICE THE EQUIPMENT CORRECTLY. FAILURE TO PROPERLY REVIEW THIS MANUAL COULD RESULT IN PERSONAL INJURY OR EQUIPMENT DAMAGE.

This manual should be considered a permanent part of the equipment and should remain with the equipment at all times. Please note the following:

Measurements in this manual are given in metric and standard U.S. measurement equivalents.

Use only correct replacement parts and fasteners. Fasteners may require specific tools.

Right and left hand sides are determined by facing forward while sitting in the seat behind the steering wheel.

THIRD-PARTY MANUFACTURER INFORMATION

This equipment contains an engine manufactured by a third-party manufacturer. This engine may be covered by the manufacturer's standard factory warranty and the manufacturer may require that all repairs and/or service be completed pursuant to its warranty terms and conditions. Please refer to the product manual and Warranty Breakdown for additional information on this warranty and any registration requirements.

TERMS AND CONDITIONS OF SALE

1. **Parties.** "Seller" means **BW Manufacturing, Inc.** "Buyer" means any entity or individual purchasing goods from Seller.
2. **Terms and Conditions of Sale.** These Terms and Conditions of Sale define the relationship of Buyer and Seller and apply to all sales of equipment (including, but not limited to Shotblasters, Scarifiers, Diamond Grinders/Polishers, Concrete Dust Collection Systems, and Trailers), components incorporated into equipment, parts, supplies, materials or other personal property (individually and collectively, "Equipment") by Seller to Buyer. Buyer acknowledges and agrees that these Terms and Conditions of Sale are incorporated in, and are a part of, any contract of sale and each quotation, purchase order, invoice, and any other document relating to the sale of Equipment by Seller to Buyer (these documents are collectively referred to as the "Agreement").
3. **Quotation Expiration.** Written quotations signed by Seller are valid for a period of 30 days unless otherwise noted by Seller.
4. **Pricing.** Prices for Equipment and other related information shown in any Seller product publication, including but not limited to catalogs, brochures, and websites, are subject to change without notice. Prices do not include related freight charges, use tax, sales tax, excise tax, value-added tax, or similar taxes, or charges of any nature whatsoever imposed by any governmental authority unless otherwise expressly noted by Seller.
5. **Taxes.** Prices quoted do not include (and Buyer shall pay) all taxes and fees of any kind that may be levied or imposed on either party by federal, state, municipal, or other governmental authorities in connection with the sale or delivery of the Equipment by Seller.
6. **Terms of Payment.** Unless Buyer has obtained credit approval from Seller, payment is due and payable to Seller in cash on completion of Seller's delivery obligation (COD). For Buyers with credit approval, any amounts due by Buyer to Seller that are unpaid on or after 30 days of Seller's invoice will bear interest at the simple interest rate of 2 percent (2%) per month or the maximum rate permitted by law, whichever is less. The accrual or payment of any interest as provided above will not constitute a waiver by Seller of any rights and remedies in connection with a default by Buyer. Buyer will pay all court costs, attorney fees, and other costs incurred by Seller in collecting past-due amounts, including interest. If shipment or delivery of Equipment is delayed by or at the request of Buyer, payment will remain due in full on the original delivery date for Buyers without credit approval or 30 days from the date of Seller's invoice for Buyers with credit approval. In either such event, Seller may impose, and Buyer shall pay, storage charges and other incidental expenses incurred by Seller as a result of the delay in addition to any interest on late payments as described above.
7. **Security Interest.** As security for payment of all amounts due to Seller, Buyer grants to Seller a security interest in all Equipment sold by Seller to Buyer, and Seller will have all rights of a secured party under the Uniform Commercial Code with respect to the Equipment. Buyer appoints Seller as its attorney-in-fact with authority, at Seller's option, to take actions as Seller deems reasonable in the circumstance to perfect the above security interest in any one or more jurisdictions, and Buyer shall pay all applicable filing fees.
8. **Limited Express Warranty.** For a period of ninety (90) days from the completion of Seller's delivery obligation under this Agreement, Seller warrants that a limited selection of components manufactured by Seller and incorporated into the Equipment will be free of defects in material and workmanship. A complete list of components covered under this warranty ("Warranty Breakdown") is available at www.bwmanufacturing.com/warrantybreakdown and is incorporated in its entirety into this Agreement. In the event Buyer has a claim related to the components covered under this warranty, Buyer shall be bound by the then-current Warranty Breakdown. Buyer's sole remedy for breach of this warranty is limited to repair and replacement, within the warranty period, of defective components manufactured by Seller and covered under this warranty pursuant to the Warranty Breakdown. Buyer is responsible for all shipping costs arising out of any warranty service provided by Seller. SELLER EXPRESSLY DISCLAIMS AND EXCLUDES ALL OTHER WARRANTIES, EXPRESS OR IMPLIED, WITH REGARDS TO THE EQUIPMENT AND/OR COMPONENTS MANUFACTURED BY SELLER AND INCORPORATED INTO THE EQUIPMENT, WHICH ARE NOT INCLUDED IN THE ABOVE REFERENCED WARRANTY, INCLUDING THE WARRANTIES OF MERCHANTABILITY AND FITNESS FOR A PARTICULAR PURPOSE. BUYER ASSUMES FULL RESPONSIBILITY THAT THE EQUIPMENT PURCHASED UNDER THE AGREEMENT MEETS THE SPECIFICATIONS AND/OR INTENDED USE OF BUYER, AND SELLER MAKES NO REPRESENTATION WITH RESPECT THERETO.
9. **Disclaimer of Third-Party Component Warranties.** THE SOLE REMEDY AVAILABLE TO BUYER WITH RESPECT TO DEFECTS IN THE COMPONENTS MANUFACTURED BY THIRD PARTIES WILL BE AGAINST THE THIRD PARTY MANUFACTURER UNDER ANY APPLICABLE MANUFACTURER'S WARRANTY TO THE EXTENT AVAILABLE TO BUYER. WITH REGARDS TO COMPONENTS MANUFACTURED BY THIRD PARTIES AND INCORPORATED INTO THE EQUIPMENT, SELLER MAKES NO WARRANTY, EXPRESS OR IMPLIED, RELATING TO THE COMPONENTS, WHETHER BASED ON BREACH OF WARRANTY OR CONTRACT, NEGLIGENCE, STRICT LIABILITY OR OTHERWISE, INCLUDING WITHOUT LIMITATION ANY IMPLIED WARRANTIES OF MERCHANTABILITY OR FITNESS FOR A PARTICULAR PURPOSE.

10. **No Consequential Damages.** IN NO EVENT WILL SELLER BE LIABLE OR RESPONSIBLE FOR ANY SPECIAL, INCIDENTAL, CONSEQUENTIAL, EXEMPLARY, OR PUNITIVE DAMAGES, OR FOR EXPENSE OCCASIONED BY THE USE OF DEFECTIVE EQUIPMENT.

11. **Delivery.** Any delivery dates or other schedule of performance by Seller are approximations, and the sole obligation of Seller with respect to the schedule of delivery or performance will be to use commercially reasonable efforts to deliver the Equipment, or otherwise to perform, consistent with the reasonable demands of its business. In any event, Seller will have no liability to Buyer or any other person for delays in performance due to strikes or labor disputes of any type; accidents, fire, floods, acts of God, or actions by governmental authorities; acts, omissions, or delays of Buyer or any other third party; shortages of labor; or without limitation of the above, for any causes reasonably beyond the control of Seller.

12. **Title and Risk of Loss.** Title to and risk of loss to the Equipment will pass to Buyer on delivery by Seller F.O.B. Seller's place of business, located at 3706 Mill Creek Dr. NE, Comstock Park, Michigan, 49321.

13. **Inspection and Acceptance.** Buyer will have two (2) days from the date of delivery to inspect the Equipment for defects and nonconformance and to notify Seller, in writing, of any defects, nonconformance, or rejection of the Equipment. After this period, Buyer will be deemed to have irrevocably accepted the Equipment. After acceptance, Buyer will have no right to reject the Equipment for any reason or to revoke acceptance. Seller is not responsible for damage to the Equipment arising out of the shipment of the Equipment to Buyer. Claims for damage due to shipping must be made by Buyer to the freight carrier.

14. **Return of Equipment.** All returns will be pursuant to Seller's instructions. Buyer must contact Seller for a Return Material Authorization (RMA) before returning any Equipment. All returns must reference the RMA number along with the original invoice number and the reason for return.

15. **Cancellation or Termination.** In the event of cancellation of the Agreement by Buyer, or in the event of default under the Agreement by Buyer that is not cured within 30 days after notice by Seller, Buyer will pay to Seller on demand all direct and indirect costs (including, without limitation, all applicable restocking or cancellation charges, including reimbursement for direct costs assessed by the manufacturer) incurred directly or indirectly by Seller in connection with the Agreement, all as reasonably determined by Seller, plus any lost profit. In no event, however, will any amount payable by Buyer under the Agreement exceed the total price payable by Buyer for the Equipment.

16. **Modifications and Waiver—Entire Agreement.** The Agreement contains the entire agreement between Seller and Buyer and can be modified or rescinded only by a writing signed by both parties. If any term of the Agreement is held invalid or unenforceable, all other terms of the Agreement shall remain in effect. Any document submitted by Buyer to Seller confirming its intention to purchase Equipment described in the Agreement will be deemed to constitute a confirmation and acceptance of the Agreement, even if the document states terms in addition to or different from those in the Agreement. All agreements between Seller and Buyer will be solely under the terms and conditions of the Agreement and Seller objects to any and all additional or different terms contained in any document submitted to Seller by Buyer. Any execution by Seller of any other document submitted by Buyer in connection with the purchase of Equipment does not constitute acceptance of or agreement to any terms and conditions in addition to or different from those contained in the Agreement, but will constitute only acknowledgment of receipt of the document. In addition, Buyer's acceptance of these terms shall be conclusively presumed by Buyer's (i) acceptance of delivery of or (ii) payment for Equipment covered under the Agreement.

17. **Compliance with Laws.** Buyer will be responsible for compliance with any and all federal, state, or local laws or regulations respecting safety or respecting use of the Equipment and shall indemnify and hold Seller harmless from and against any and all claims of violations of laws or regulations or other claims of personal injury or property damage directly or indirectly related to the installation, maintenance, or operation of the Equipment.

18. **Export Control.** Equipment supplied by Seller may be subject to various export laws and regulations. It is the responsibility of the exporter and Buyer to comply with all laws and regulations. If any required export authorization is denied, Seller will be relieved of any further obligation related to the sale and delivery of the Equipment.

19. **Governing Law and Venue.** This Agreement will be governed by and construed in accordance with the laws of the State of Michigan. Buyer submits to personal jurisdiction in Michigan. Seller and Buyer agree that any action arising out of the sale of goods or services in accordance with this document will be brought, heard, and decided in a court located in Kent County, Michigan and that this venue is convenient. .

20. **Authority.** Each signatory represents that it has all requisite authority to execute the Agreement on behalf of its principal and that the Agreement is fully enforceable against the principal in accordance with its terms.

B W MANUFACTURING, INC.

GENERAL SAFETY & HAZARDOUS MATERIALS WARNING

WARNING SURFACE PREPARATION EQUIPMENT CAN BE DANGEROUS IF NOT OPERATED PROPERLY. THE OPERATOR IS RESPONSIBLE FOR THE SAFE OPERATION OF THIS EQUIPMENT. The operator must carefully read and follow any warnings or safety instructions provided with the equipment prior to operating the equipment. Do not remove any safety devices or warnings on the equipment.

WARNING FLOOR AND/OR DECK SURFACES MAY BE COATED WITH OR CONTAMINATED BY HAZARDOUS MATERIALS. Typical examples of hazardous materials include (i) tile mastic (likely to contain *asbestos*); (ii) stained areas near electrical equipment (potentially containing *PCBS*); (iii) paint (potentially containing *lead*); (iv) stained floor areas in chemical or other industrial facilities (potentially containing toxic *pesticides, cleaning fluids, solvents, or other harmful chemicals*).

WARNING Preparation equipment is used to remove surface material from a variety of surfaces. The surface preparation process often generates large amounts of dust and other small particles, which are released into the air. WHEN A SURFACE CONTAINS HAZARDOUS MATERIALS, EXPOSURE TO THE DUST GENERATED BY THE PREPARATION EQUIPMENT MAY POSE A HEALTH RISK. INSPECT ALL SURFACES FOR POSSIBLE CONTAMINATES PRIOR TO USING PREPARATION EQUIPMENT AND CONSULT HAZARDOUS MATERIAL EXPERTS AND GOVERNMENT AUTHORITIES BEFORE OPERATING PREPARATION EQUIPMENT ON SURFACES SUSPECTED OF CONTAINING HAZARDOUS MATERIALS.

WARNING BW MANUFACTURING, INC. IN NO WAY REPRESENTS THAT ITS PREPARATION EQUIPMENT IS SUITABLE OR APPROVED FOR REMOVING HAZARDOUS MATERIALS FROM CONTAMINATED SURFACES. DO NOT ATTEMPT TO USE ANY PREPARATION EQUIPMENT MANUFACTURED BY BW MANUFACTURING, INC. ON ANY CONTAMINATED SURFACE. It is the responsibility of the preparation equipment operator and/or the contractor using the preparation equipment to inspect the proposed worksite for contaminants and obtain approval from contamination experts and/or government authorities before using BW Manufacturing, Inc. preparation equipment. It is also the responsibility of any contractor using preparation equipment to inform its employees or subcontractors of all potential health risks associated with operating preparation equipment and to ensure its employees or subcontractors are protected from exposure to harmful materials.

BW MANUFACTURING, INC. IS NOT RESPONSIBLE FOR ANY INJURY, ILLNESS, DEATH, OR PROPERTY DAMAGE THAT MAY RESULT FROM IMPROPER USE OF ITS PREPARATION EQUIPMENT OR OTHER PRODUCTS

WARRANTY BREAKDOWN

Item	NONE	90 DAYS	1YEAR / 500 HR	2 YEARS / 2000HR	WARRANTED BY:
Chassis		○			B W Mfg., Inc.
Engine				○	Briggs & Stratton
Clutch			○		B W Mfg., Inc.
Compressor			○		B W Mfg., Inc.
Hydraulics			○		B W Mfg., Inc.
Dust Filters	○				B W Mfg., Inc.
Blast Head		○			B W Mfg., Inc.
Blast Wheel	○				B W Mfg., Inc.
Scarifier Head		○			B W Mfg., Inc.
Scarifier Cage	○				B W Mfg., Inc.
Scarifier Main Shaft	○				B W Mfg., Inc.
Diamond Grinder/ Polisher Head		○			B W Mfg., Inc.
Diamond Mount	○				B W Mfg., Inc.
Diamond Cutters	○				B W Mfg., Inc.

WARRANTED BY:	Company to Contact
Kubota Engine America Co.	Engine Power Inc.
	1-800-832-7670
	www.enginepower.com
B W Mfg., Inc.	B W Manufacturing, Inc.
	Voice: 616-447-9076
	Fax: 616-447-9078
	E-mail: info@bwmanufacturing.com
	Warranty does not include travel time

SC-12 SCARIFIER HEAD INSTALLATION

Scarifier Head Removal & Installation

Disconnect dust collection hose (A). Remove head stop locking pin (B) and remove bolt (C) to rotate belt tension adjuster (D) towards front of machine. Slide scarifying head towards machine, remove drive belts and slide head forward off lift support shaft (E). To install scarifying head simply reverse removal instructions.

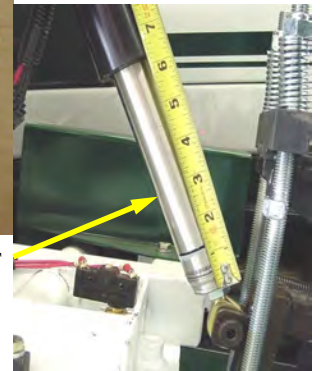
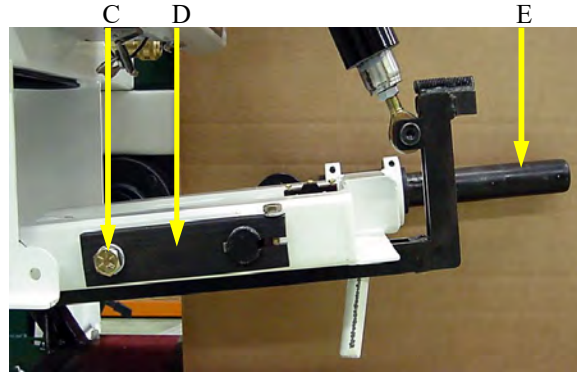
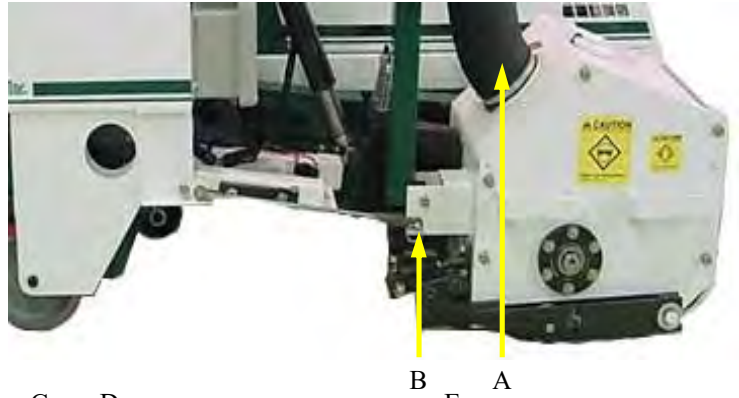

Lift Cylinder Settings

The lift cylinder is factory set at 6¼” fully extended (F). For adjustment please contact BW Manufacturing.

To Interchange Sheaves

Slide bushing onto shaft flange first and flush with the end of the shaft, slide sheave on to bushing. Align bolt holes using the threaded holes of the bushing to draw the sheave tight. Tighten bolts (A) alternately and evenly to 95 inch pounds. The bushing should remain flush with the end of the shaft to ensure proper alignment (C). To remove the sheave from the machine, simply remove the bolts (A) from the sheave and place them in the threaded holes (B) tightening bolts alternately in small increments separating the sheave from the bushing.

PTO sheave for
Diamond Grinder/Polisher,
Scarifier Head, & Broom/
Magnet Attachments

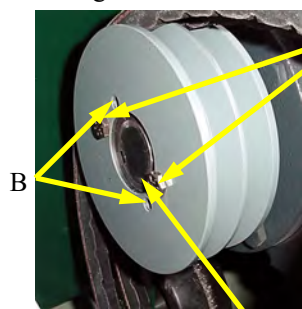

PTO sheave for
Blast Head
Attachment

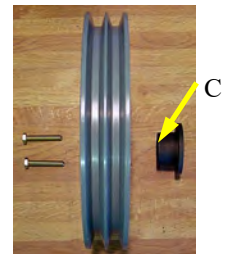
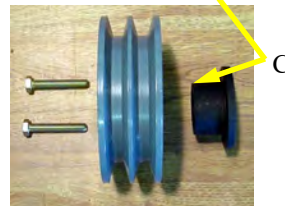
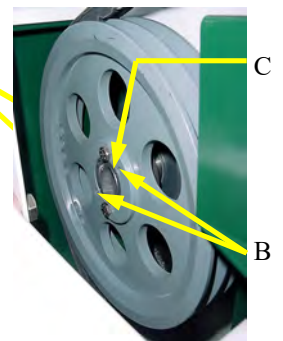

SC-12 SCARIFIER HEAD INSTALLATION

Installing cutters on cage.

Alternate cutters and washers on cage shafts. For best results, use thick hardened washers (part # SC-1628) and keep the same number of cutters on each shaft. For proper balance use extra washers as needed. When reusing shafts, install shafts the same direction they were removed so that the shaft wear marks align with the cage supports. When reusing washers and cutters, inspect each one for hair line cracks. If cracks or breaks are spotted **DO NOT USE**.



Cage with carbide cutters



Cage with steel cutters

Installing cage into head.

First loosen belt tensioner arm and move to the forward position, remove side cover, install alignment shaft (A) into the end of the hex drive shaft and raise head to align shaft to cage and slide cage into the machine. Install side cover. Remove alignment shaft and tighten belt tensioner.

To remove cage

Reverse the previous process.

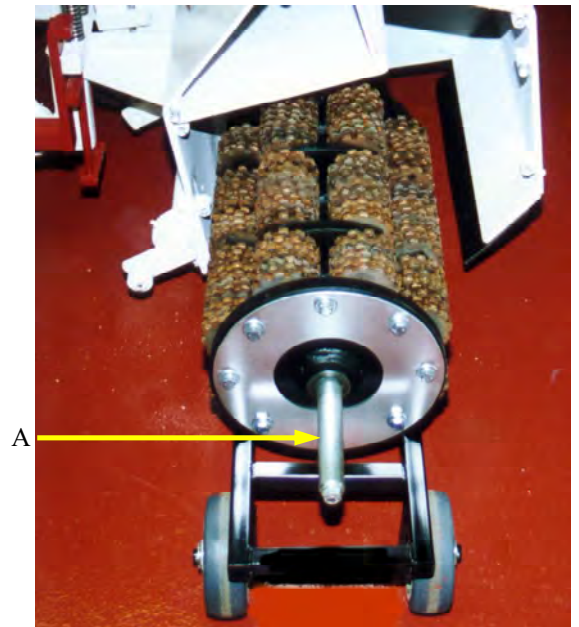

SC-12 SCARIFIER HEAD OPERATION

****NOTE****

Machine is to be run at wide open throttle when using the SC-12 Scarifier head attachment

Checking spring tension.

Lower head with Lift Switch until lift cylinder and Lift Arm (D) are all the way down to achieve proper spring tension. Tension Springs (E) should have a gap so that a business card could slide through. To adjust, move spring base plate (F) either up or down to achieve proper spring tension.

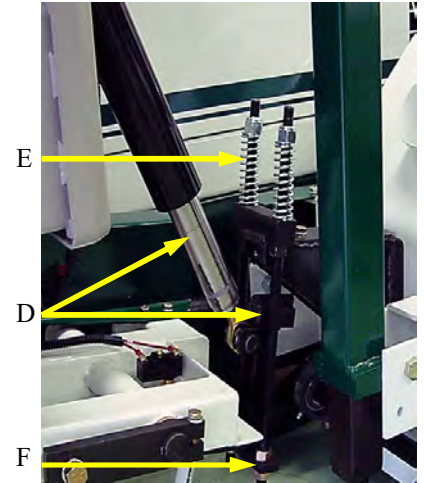

Setting cutting depth.

Run engine at wide open throttle. Lower Scarifier Head to surface. Turn adjuster knob (A) until cutters make contact with surface. Raise head and turn adjuster knob FOUR (4) full turns down (Clockwise) to establish proper cutter depth.



A

****CAUTION****

Lowering cutter adjuster to far will cause cage shafts to pinch cutters between the shaft and the surface (F). This will cause cutters, shafts, and cage to break. The cutters should be able to move freely around the shaft at all times (G).

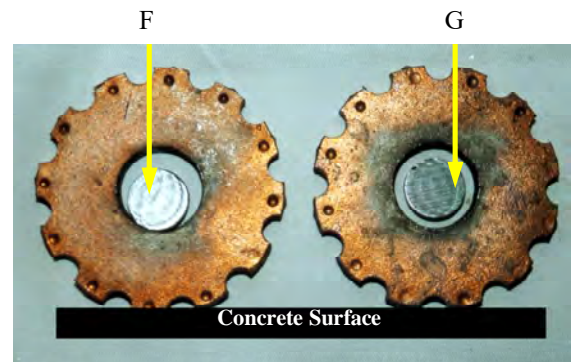

SC-12 SCARIFIER HEAD SERVICE

To check head cut.

Use two equally thick spacers between the adjuster arm and main bearing blocks on each side of the scarifying head. (A). Adjust rear pillow block bearings until rollers (B) make contact with top of adjuster arm on each side of the head.

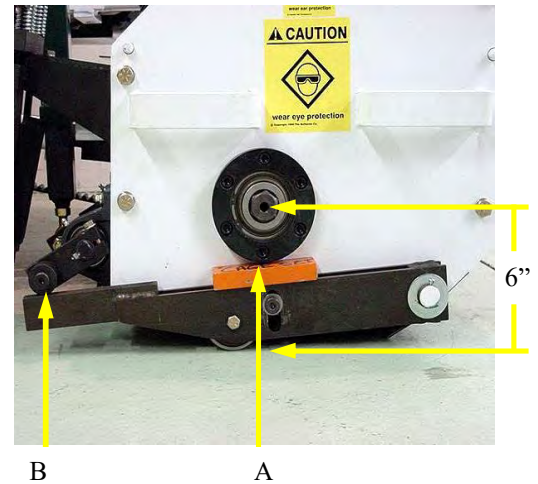

To set head alignment.

With the machine on level ground and the centerline of the main shaft is 6" off the ground, use a square and set the front top of the scarifier housing tight to the square and have a 1/8" gap from lower front of housing to square (C).

To adjust, loosen mount bolts (E). Align mount, tighten bolts (E).

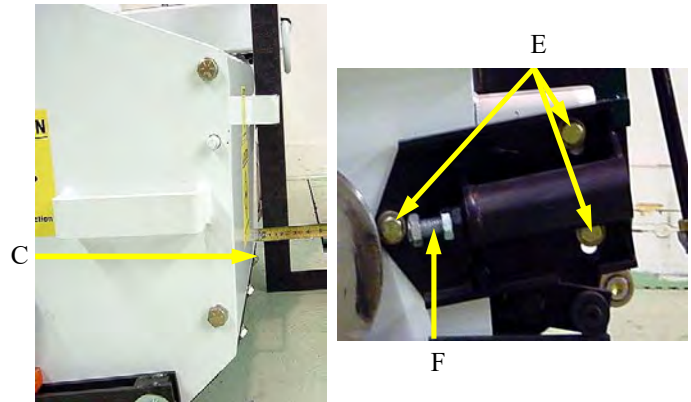

Belt Tension Adjustment

Once the scarifier head is installed on the machine place the belt tension arm in the rearward position and adjust bolt (F) to set proper belt tension. Belts should be able to be pulled no more than 1" in the upwards direction (G).

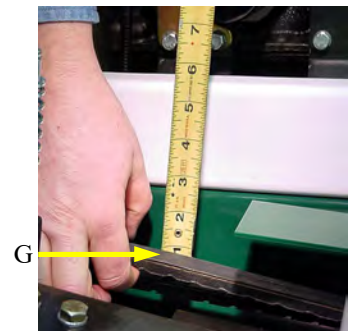

Head Lift Adjustment

If scarifier head lifts uneven, loosen 3 bolts on bracket (H) and adjust bracket as needed. Lowering bracket will raise outer side of head. Adjust head alignment prior to this adjustment.

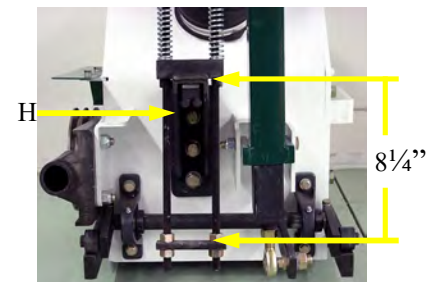

SC-12 SCARIFIER HEAD PARTS

1. F-1201 Dust Hose
2. E-2105 Dust Hose Clamp
3. H-006-AS Belt Guard
4. O-57-AS Scarifier Head Lift Mount
5. 5/8-11JN Jam Nut
6. S-042-D Tension Bolt
7. S-002-LAS Left Adjuster Arm
8. S-007-DAS Housing (less S-004-AS side cover)

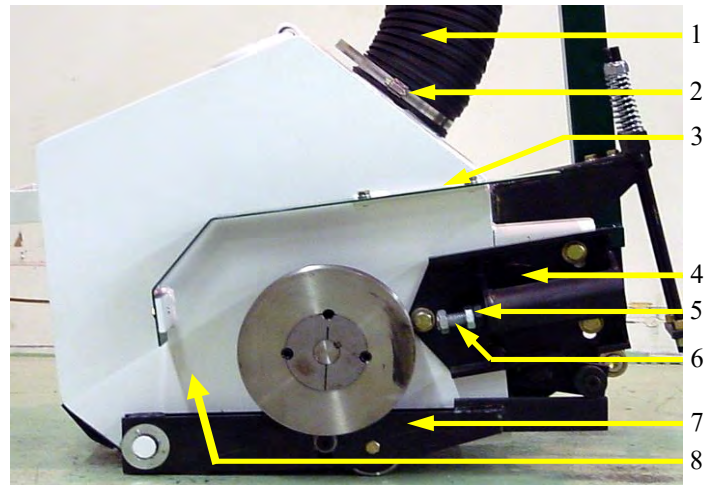

1. S-004-AS Side Cover
2. S-002-RAS Right Adjuster Arm

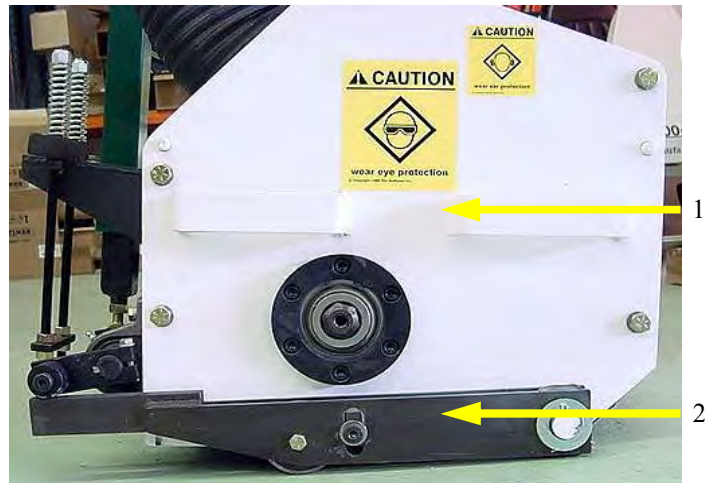

1. H-038-D Front Seal Backing Plate (Not Shown)
2. H-037-DAS Front Seal Plate
3. S-043-D Front Seal



SC-12 SCARIFIER HEAD PARTS

1. F-1203 Tension Spring
2. S-047-DAS Lift Grip
3. S-049-AS Spring Rod
4. SC-1618 Adj. Control Bearing
5. S-017 Outer Adjuster Arm
6. S-031 Adjuster Roller
7. 3/8-16X1/2X1 SB Shoulder Bolt
8. S-016-D Adjuster Arm Assembly
9. S-038 Spring Base Plate
10. S-033-DAS Rear Lift Mount Assembly
11. S-041-AS Adj. Control Assembly
12. 3/8ETFW Thick Flat Washer 3/8"

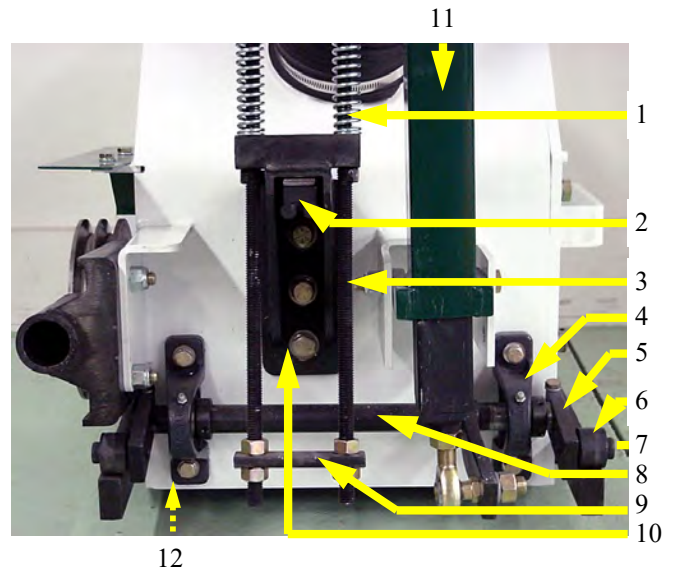

1. SC-1613 Ball Joint
2. S-064-A Inner Adjuster Tube
3. S-055-AS Adjuster Screw
4. S-053 Adj. Tube Resistance Block
5. A-8625 Tension Spacer
6. A-8631 Adjuster Bushing
7. S-041-AS Outer Adjuster Tube
8. A-8557 Rubber Washer
9. S-067 Adjustment Knob
10. A-8590 Roll Pin

*Unit can be purchased as an assembly
using part number A-041-AS*

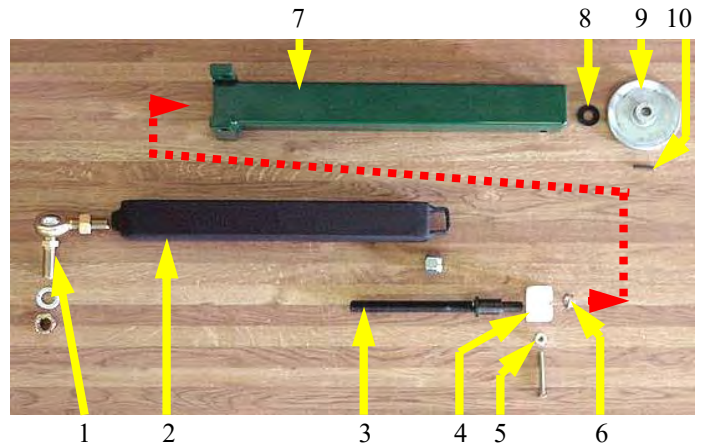

O-82-AS Wheel Weight *(used with scarifier head only)*



SC-12 SCARIFIER HEAD PARTS

1. SC-1625 Outer Bearing Snap Ring
2. SC-1631 Outer Bearing
3. S-001-D Outer Bearing Mount
4. S-003-D Main Shaft
5. S-066 Main Shaft Inner Collar
6. S-001 Inner Bearing Mount
7. SC-1620 Inner Bearing
8. SC-1624 Inner Bearing Snap Ring
9. S-058 Main Shaft Outer Collar
10. 3/8-16x1-1/4 Grade 8 Bolt (6 each)
11. SC-1619 Bearing Mount Bolt (6 each)
12. F-1205 Drive Bushing
13. F-1206 Drive Sheave

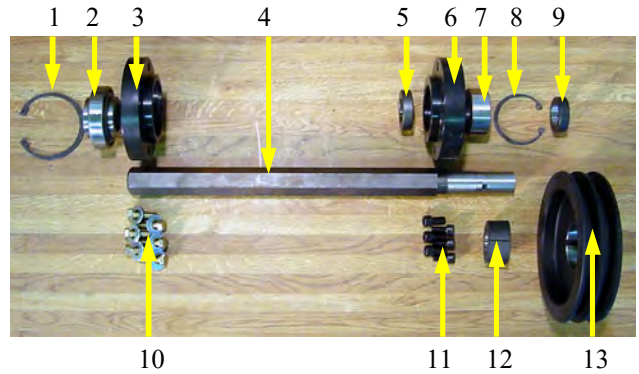

1. S-002-AS Adjuster Arm (specify side R or L)
2. 3/8-16JN Jam Nut
3. 1SAEFW Washer
4. V-1035 Cotter Pin
5. SC-1634 Adjuster Arm Shim
6. SC-1621 Adj. Arm Bearing
7. S-026 Adj. Arm Bearing Spacer
8. SC-1619 Adj. Arm Bearing Bolt
9. 3/8-16X1/2X1-1/4 SB Shoulder Bolt
10. SC-1635 Adjuster Arm Spring Washer

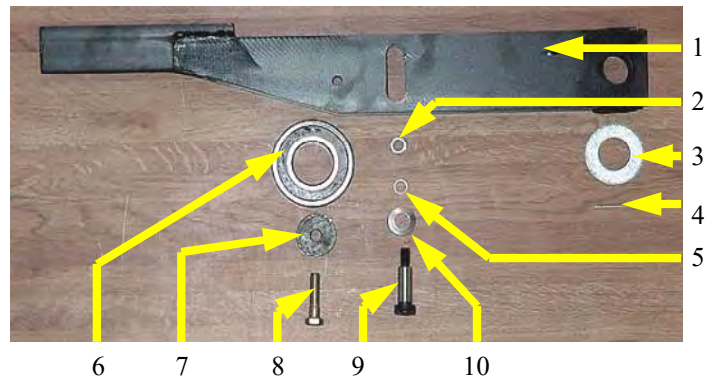

1. N-01-AS Cage End Plate
2. S-012-A2 Standard Cage (Bare)
3. S-048-D Cage Shafts (requires 8 each)
4. SC-1630 Steel Cutter (requires 240 pcs.)
5. A-16C12 Carbide Cutter (requires 168 pcs.)
6. SC-1628 Cage Spacer (Equal Amount To Cutters)

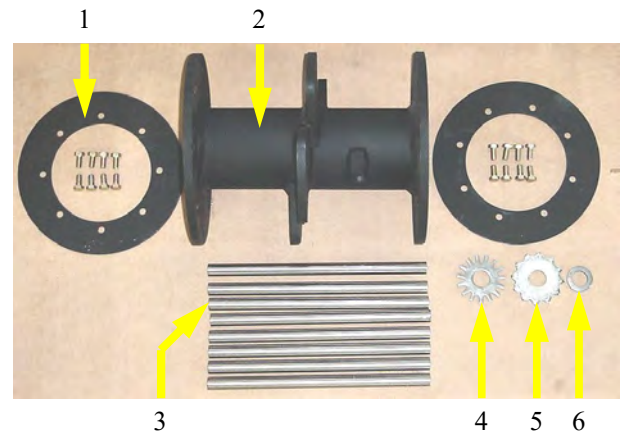

Assembled Cage Options

- S-012-AS Bare Cage with Shafts & End Covers
- S-012-DAC Cage with Shafts, End Covers, Carbide Cutters and Washers
- S-012-DAS Cage with Shafts, End Covers, Steel Cutters and Washers

Page
Left
Intentionally
Blank